



Highway





Built for the long haul.

Mack® highway trucks carry more than cargo. They move your business forward. That's why we've armed our highway trucks with every advantage possible. Reliable, fuel-efficient and driver-friendly, the Mack Anthem® and Mack Pinnacle™ tractors are built for your business and designed for the driver.

CONNECTED FOR UPTIME

Equipped with Mack's productivity and uptime technologies, our highway trucks stay on the road and out of the shop.

DRIVER-FOCUSED

Redesigned interiors are built around the way work gets done on the road, keeping drivers more comfortable and productive than ever.

MACK TOUGH

The industry has trusted their toughest jobs to Mack for generations. Built in America from light, yet durable materials, our highway trucks stand up to the rigors of the road.

LIGHTWEIGHT AND EFFICIENT

Mack's fully integrated powertrain combines fuel economy and lightweight power to deliver highway trucks that drive down costs.

Meet the heroes of the highway.



Mack Anthem® Day Cab
Next-generation efficiency.



Mack Anthem® 70-inch Stand Up Sleeper
Designed for the long haul.

Mack® Pinnacle™ Day Cab
Legendary toughness.

Ready for any road.

Whether you're covering 10 miles or 10,000, you can count on Mack® highway trucks to get you there. No matter the job, the Mack Anthem® and Mack Pinnacle™ deliver the strength, comfort and efficiency you need to tackle whatever the road brings.



Long Haul

The ergonomic driver environment and spacious, stand up sleeper in Mack Anthem keeps drivers comfortable, mile after mile.



Regional Haul

Clean wheel cuts provide the easy maneuverability the road demands.



Flatbed

Pinnacle has the power and performance to handle the heaviest hauls.



Bulk Haul

Spec'd for bulk haul, the lighter weight of Mack Anthem reduces fuel consumption and maximizes payload.



LTL/Van Haul

The bold, aerodynamic design of Mack Anthem makes your runs faster and more efficient than ever.

Mack Anthem[®]

We took more than a century of experience building America and put it to work tackling the challenges of our industry. The result? The new Mack Anthem—a truck that will make you rethink what's possible on the highway. Boldly designed and engineered tough, Mack Anthem is born ready for whatever the road demands.

Built for your business.

Efficient in every sense of the word, Mack Anthem saves on fuel and reduces maintenance costs while maximizing uptime—and your bottom line.

Designed for the driver.

The cab design and driver environment of Mack Anthem are built around the way work gets done on the road, keeping drivers comfortable, safe and focused all day long.

Command the road.

The intuitive instrument panel and steering wheel of Mack Anthem give drivers total confidence and control in the cockpit.

Comfort for the long haul.

A spacious interior and American craftsmanship give drivers the comfort they need to feel at home.

Utility from top to bottom.

Configure the best-in-class storage in Mack Anthem for as much or as little as you need to store.



Day Cab

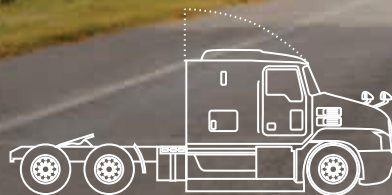

48-inch Flat Top Sleeper

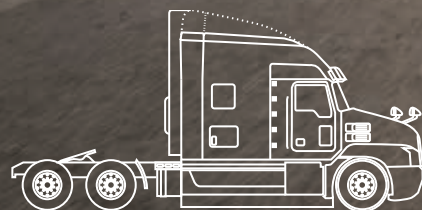

70-inch Stand Up Sleeper





Aerodynamic never looked so Mack.

The Mack Anthem® challenges the expectations of aerodynamic design with a bold look that dramatically improves efficiency up to 3%.



Roof Fairings with Adjustable Trim Tab

Improves airflow from the cab to the trailer (70-inch Stand Up Sleeper only).

Hood and Fenders

Hood slope and fender design directs air over and around the trailer.

Bumper Close-Out Flange

Prevents airflow between hood and bumper and moves air around the cab.

Air Dam

Reduces turbulence under the vehicle for less drag.

Hood Mirrors

Single support decreases wind resistance compared to tripod designs and folds on impact to prevent damage.

Covered Tow Loops

Cuts down on wind resistance and creates a clean look.

Built to last.

Mack Anthem[®] drives down operating costs with durability that stands up to the rigors of the road and keeps you out of the shop.



Breakaway Hood Mirrors

The mounts are spring-loaded to rotate when hit, preventing damage to the hood and lowering parts and repair costs.

Breakaway Side Mirrors

Strong hinges with zero plastic, tougher materials and spring-loaded mounts help keep maintenance costs down.

LED Lights

LED headlights are 66% brighter, last longer, use less energy and provide better visibility.

Durable Components

From bolts to latches, all Mack Anthem components are made from tough, long-lasting materials.



3-Piece Hood

The 3 pieces are bonded together but can be separated and repaired individually for lower replacement costs.



3-Piece Bumper

The 3 pieces can be ordered as separate replacement parts for improved serviceability and lower repair costs.

Mack® Pinnacle™

From heavy loads to steep grades to long hauls, Pinnacle is up to whatever challenges the job throws your way.

Axle-Forward Configuration

Forward axle position spreads the load to maximize your payload.

Durable Components

Reinforced and redesigned with new materials to be tougher than ever.

Advantage™ Chassis

Advantage Chassis frame rails support heavy loads, even on challenging terrain. And Pinnacle's spread frame rails places the engine and transmission lower in the chassis, improving stability with a lower center of gravity.

Ground Clearance

High ground clearance for taking Pinnacle off-highway.



Day Cab



48-inch Flat Top Sleeper



70-inch Stand Up Sleeper



Less maintenance, more uptime.

On-road, off-road, or anywhere in between, Mack builds Pinnacle™ to stay on the job. Using the finest parts and rugged engineering, we aim to keep your trucks out of the shop and out on the haul.

HuckBolts®

Precision-engineered to lock down and stay locked, two-piece HuckBolt fasteners hold our Mack chassis tight, no matter how rough the ride.



Advantage™ Chassis

Advantage chassis frame rails support heavy, demanding loads on any terrain.



LED Lights

Brighter, more energy efficient, and longer-lasting, LED headlamps light the way to increased uptime.

Axle-Forward Configuration

Forward axle position spreads the load to maximize payload and minimize stress.

Control at your fingertips.

Built to work and designed with purpose, automotive-inspired controls in the driver environment make operation easy, safe and comfortable.

Illuminated Controls

Keep eyes on the road with familiar, automotive-style controls.

Flat-Bottom Steering Wheel

An industry-first, allowing more belly room and clearance for entry or exit. Add to that a racecar-style grip, enhanced dash visibility and clipboard-friendly surface for better control and maximum comfort.

Information and Entertainment Display

7" touchscreen, along with smart steering wheel buttons, manages tools like SiriusXM®, Weather Band, TomTom truck navigation, Apple CarPlay and optional back-up camera.

D-Panel Gauges

Customize the dash with 4 optional auxiliary gauges.

Power Window, Lock and Mirror Controls

Provide more comfort and control than manual windows.

Light Control Module

Runs all exterior lights from one place with an automotive feel.

Rocker Switches

New larger, robust rocker switches are laser etched to be readable for life.

Right Stalk

Manages engine brake and Co-Pilot™.

mDRIVE™ Controls

Intuitive placement—and the option to install it even higher on the dash—gives drivers comfortable access without taking eyes off the road.

Left Stalk

Manages high beams, self-canceling turn signals and wipers.

Built to work.

Durable, comfortable and functional, new Mack® interiors keep drivers fresh and focused for as long as they're on the road.

Non-Slip Electronics Tray

Charge electronics securely with the USB port, phone holder and non-slip rubber fuse relay center cover.

Front Overhead Console

Generous storage with tough materials, interior LED light controls and a dedicated CB radio box.

Mack® Co-Pilot™

5" full-color digital display provides enhanced visibility and simpler navigation without distractions. Constant truck monitoring and Pre-Trip Assistant, including one-person Exterior Light Inspection, help keep an eye out for potential issues before they become real ones.

Additional Storage

Oversized cup holders fit large drinks, plus plenty of room for keys, devices and more in one easy-to-clean unit.



Mack-Exclusive Seats

We partnered with Sears Seating to build seats that improve driver comfort and support, while taking on daily wear and tear.

- Air suspension
- Optional swivel base
- 30+ feature and fabric combinations



Sleeper Windows



Sleeper Control Panel



Amenities



Sleeper Lighting



Flexible Work Space

Home away from home.

We built the the Mack® highway sleepers with more space than ever to give drivers plenty of room to get comfortable, rest well and stay focused on the road.

AMENITIES

Opt for a spacious, stainless steel refrigerator or choose from prep kits—including power outlets—for a refrigerator, microwave or flat-screen TV. Add cup holders with integrated storage above the bottom bunk for easy access to everything.

SLEEPER WINDOWS

Sleeper windows feature self-contained built-in blackout shades. The screened windows tilt out to let air in and keep rain out.

SLEEPER CONTROL PANEL

Access power outlets and USB ports and control the sleeper stereo, interior lighting and high-performing HVAC from one convenient panel.

SLEEPER LIGHTING

Dimmable pipe light around the perimeter of the driver environment, bunk task light, reading lights and overhead lights are all bright, long-lasting LED.

FLEXIBLE WORK SPACE

Versatile pullout surfaces behind the driver and passenger seats create a comfortable space for a meal or catching up on email.

IDLE-FREE POWER

Idle Free® electric APU lets drivers run the HVAC system without idling, saving fuel and maintenance costs.

Everything in its place.

Mack® sleepers offer cabinets, work surfaces, wardrobes and shelving to keep the living space organized, functional and ready to work.

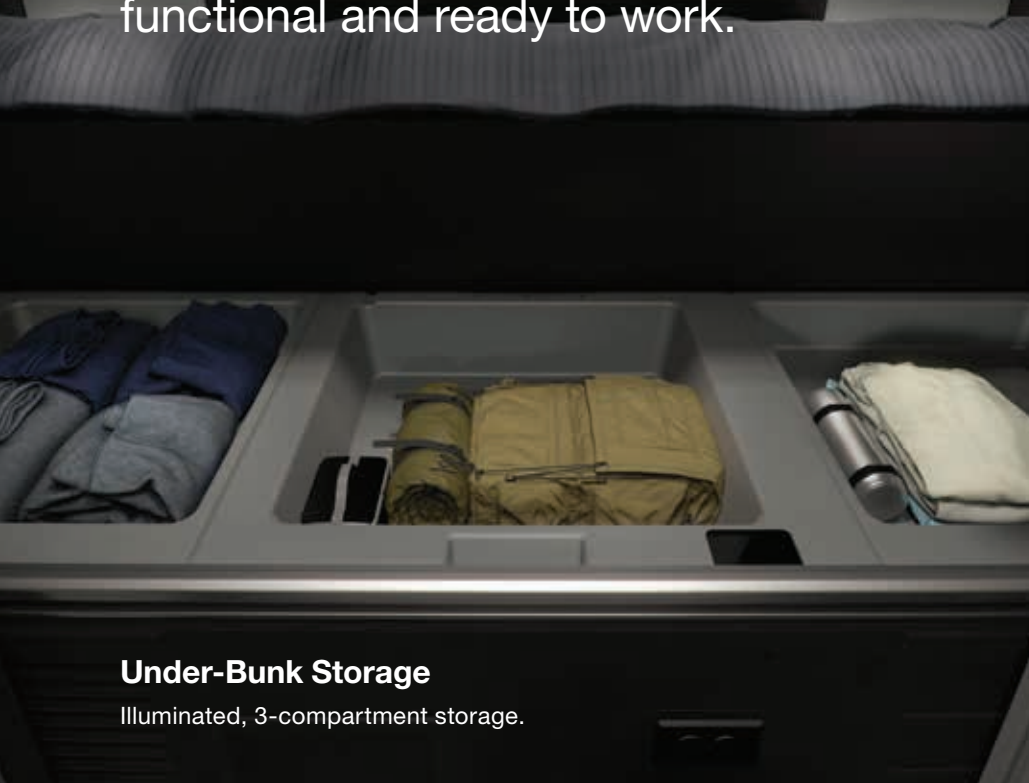

Under-Bunk Storage

Illuminated, 3-compartment storage.



Bunk Wall Storage

Back wall cup holder and open storage bin or 3-cabinet overhead storage (single bunk only).

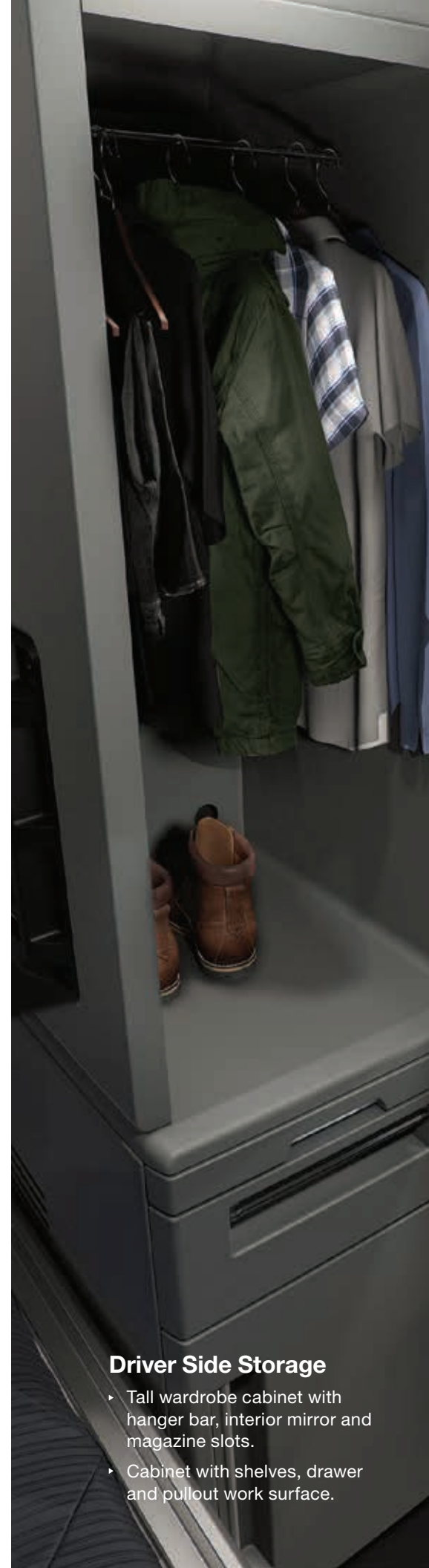

Driver Side Storage

- ▶ Tall wardrobe cabinet with hanger bar, interior mirror and magazine slots.
- ▶ Cabinet with shelves, drawer and pullout work surface.



Passenger Side Storage

- ▶ Microwave cabinet, DVD/storage slot, top storage.
- ▶ TV prep kit (up to 24" flat panel), mounting brackets, power outlet.
- ▶ Drawer-style refrigerator and storage drawer.
- ▶ Microwave, TV and refrigerator spaces are also available as cabinets.

Form meets function.

Mile after mile, job after job, keep your drivers focused and rolling with interior options that are as comfortable as they are functional.

BUNKS AND STORAGE

*Additional storage options available; contact your Mack dealer for more information.



Single Bunk
with lower storage



Single Bunk
with full storage



Double Bunk
with full storage

DASH AND INTERIOR TRIM PACKAGES



Standard

- Gunmetal dash
- Charcoal door trim
- Steel Gray interior trim
- Interior trim also available in Sierra Tan (Day Cab only)



Premium

- Aluminum dash and door trim
- Steel Gray interior trim
- Interior trim also available in Sierra Tan (Day Cab only)



Ultra

(70-inch Stand Up Sleeper only)

- Woodgrain dash and door trim
- Steel Gray interior trim with Dark Saddle inserts

SEATS



Standard

Durable vinyl construction for low maintenance and easy cleaning.



Premium

Vinyl construction and cloth inserts combine style with performance.



Ultra

Ultraleather® in Dark Saddle for a premium feel that delivers comfort and durability.

STEERING WHEELS



Standard

Urethane foam rim
Gunmetal spokes
All controls located on the D-panel
Also available with steering wheel controls and Satin Aluminum spokes



Premium

Leather-wrapped rim
Leather horn pad
Satin Aluminum spokes
Steering wheel controls



Ultra

(70-inch Stand Up Sleeper only)
Leather-wrapped rim with Dark Saddle leather inserts
Leather horn pad
Satin Aluminum spokes
Steering wheel controls

Powered by Mack's integrated powertrain.

Engineered for efficiency and performance, and proudly assembled in Mack's Hagerstown, Maryland facility, our integrated powertrain is the toughest in the game. Bar none.



Mack® MP® Engines

With horsepower, torque and superior fuel economy, Mack's MP engines conquer the highway, mile after mile.

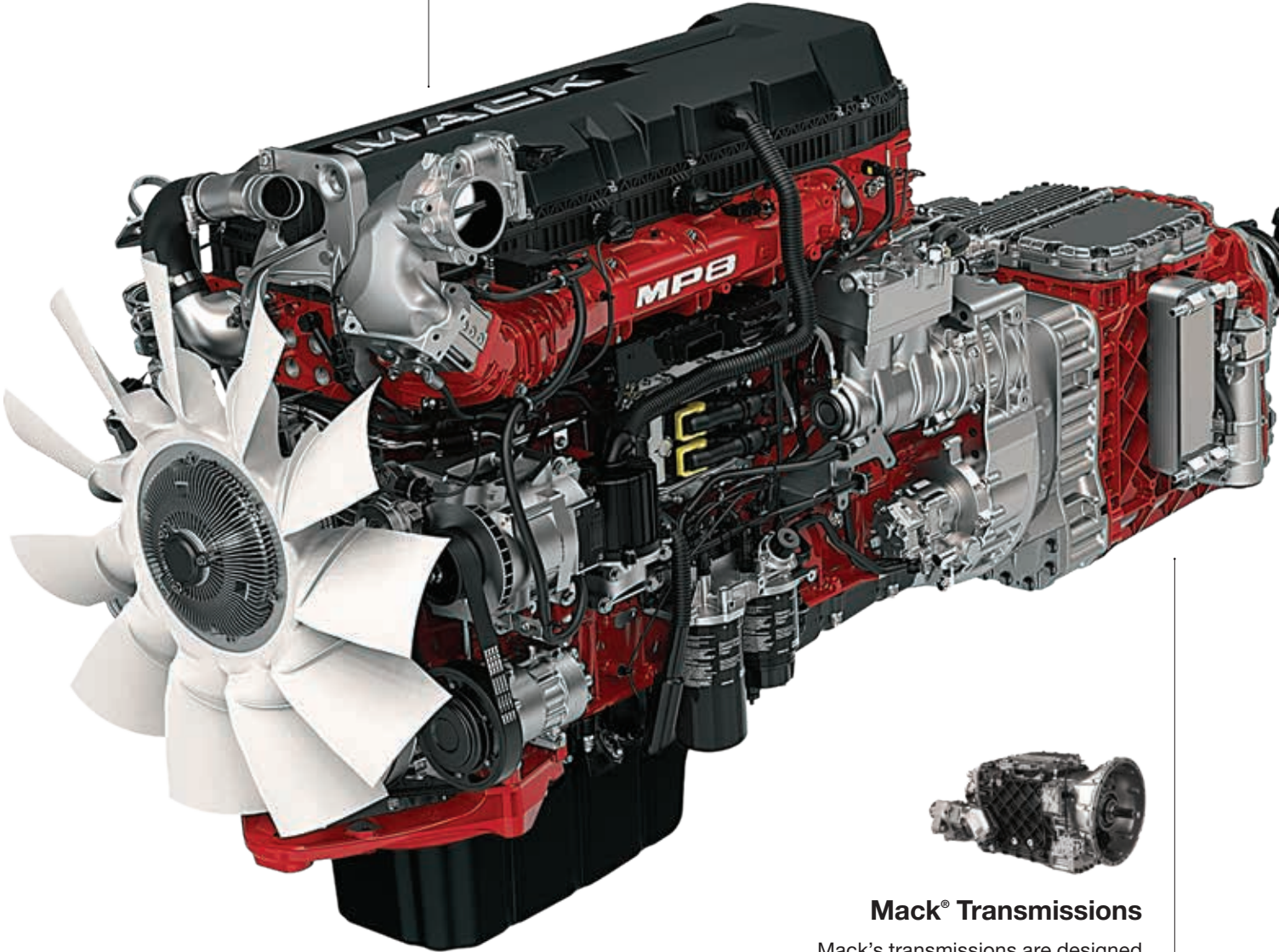

Mack® Transmissions

Mack's transmissions are designed and built to perform at the highest level in the most demanding conditions, just like the rest of the truck.



Mack® Axles and Axle Carriers

The durable S38/40 series drive axles and the rugged C125/126, C150/151 and 200 series axle carriers deliver improved reliability, impressive fuel economy, and a smooth, quiet ride.



6x2 with Liftable Pusher Axle

The 6x2 suspension with Liftable Pusher Axle for the Mack Anthem® delivers 3-to-5% improved fuel economy and saves up to 300 lbs in weight for regional, bulk, tanker and liquid hauls.

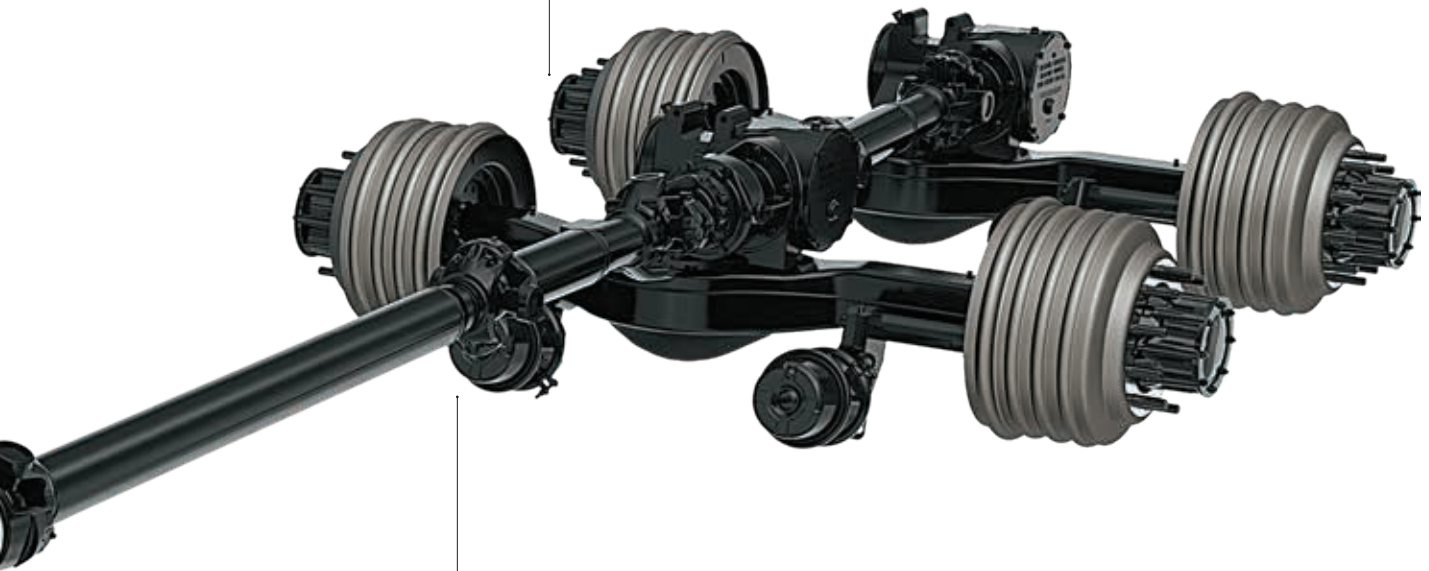

mRIDE™ Spring Suspension

Lighter than the competition, the *mRIDE* spring suspension offers extreme articulation and constant ground contact for all wheels to maximize traction and improve stability. Shock absorbers dampen the reaction of the suspension, while parabolic springs bring flexibility for an easier ride in both loaded and unloaded conditions.



Twin Y Air Suspension

The Mack Twin Y air suspension is the trucking industry's first suspension to utilize an innovative Y-shaped high-strength steel design. The Twin Y is up to 400 lbs. lighter than other air suspensions, offering a significantly lighter weight option.

The heart of a legend.

Mack® engines deliver the fuel economy, power and unmatched reliability you have come to expect. And with updates to meet GHG17 standards, Mack engines run cleaner than ever.



MP®8
now with turbocompounding.

MP®7 ENGINE

The lightweight MP7 engine has evolved to run even cleaner, emitting less CO2 than ever before while maintaining 325-425 HP.

MP®8 ENGINE

With an outstanding power-to-weight ratio and plenty of torque, the 13-liter MP8 delivers fuel efficiency, muscle and increased uptime.

MP®8-TC ENGINE

The MP8-TC with turbocompounding captures lost energy and converts it to power, burning up to 9% less fuel in highway operations.

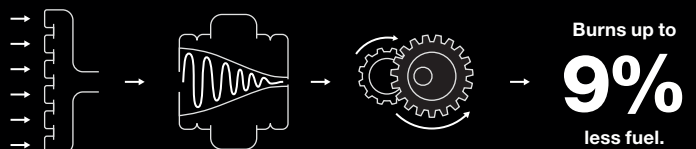

Hot exhaust captured from engine.

Exhaust gas converted to mechanical energy by turbo unit.

Turbo delivers torque to the crankshaft.

WAVE PISTON DESIGN

- By adding small waves to the piston bowl, the engine can burn fuel more efficiently for reduced fuel consumption and lower emissions.
- Meets GHG17 standards.

Combustion chamber burn patterns



Standard piston combustion efficiency



Mack Wave piston combustion efficiency



NATURAL GAS ENGINES

When cutting emissions matters, natural gas engines provide the cleanest option on the market. Equipping your truck with a Cummins-Westport natural gas engine gives you multiple lower-cost fuel options and drives emissions to near zero.

CLEARTECH™ ONE

New and improved exhaust aftertreatment system is lighter and takes up less space, which saves fuel and money while improving flexibility. And it continues our tradition of low maintenance, increased uptime and lower total cost of ownership.



The future of highway hauling.

Built in America with tough materials and proven technology, Mack's *mDRIVE™* and *mDRIVE™* HD automated manual transmissions not only deliver smooth shifts every time, but also maximize driver comfort, payload and fuel economy.



mDRIVE™

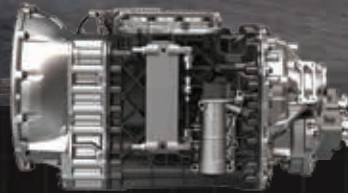

More Fuel Efficient

mDRIVE continuously monitors changes in grade, acceleration, vehicle weight and more to optimize fuel economy.

Easier to Operate

Drivers can manage *mDRIVE* with just the press of a button, making it more comfortable and easier to operate, even for new drivers.

Increased Uptime

Proven technology and superior design mean *mDRIVE* requires minimal service, significantly reducing maintenance costs and downtime.

Shift to a higher standard.

Offering instantaneous pulling power, smooth shifting and exceptional control at low speeds, the Mack Maxitorque® ES T300 features the industry's only triple countershaft design and one piece aluminum case, and it offers the most PTO mounting options out there.

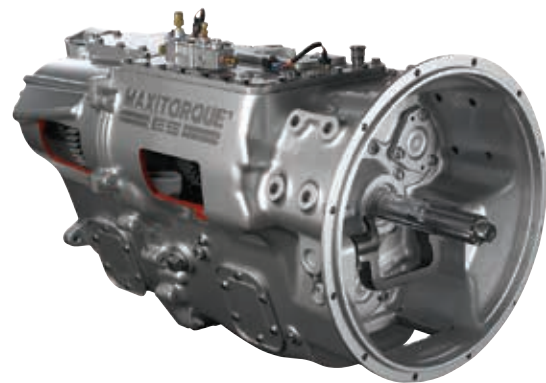

PURPOSEFUL POWER

Delivers the desired torque to provide instantaneous pulling power to match the demands of the most severe roads.

SMOOTH SHIFTING

Features a shift rail profile and light-touch design that allows for smooth transitions in and out of neutral with each shift. And because it's so smooth, drivers experience increased comfort.

UNMATCHED MANEUVERABILITY

Offers low and low-low ratios for exceptional maneuverability and slow speed control. Plus, our exclusive, shiftable, multi-speed reverse provides advanced precision.

Uptime. All the time.

Mack® Connect is the productivity solution to help you build a modern trucking business. Using predictive analytics and connective technologies, Mack Connect turns data produced by the truck, the driver and the service process into insights and actions that help you perform at your best.

Connected Driving



Connected Business



Connected Support



Connected Business

To succeed in the modern trucking industry you need to run a modern trucking company. Drive profitability and gain insights at every turn with Mack's fleet management systems. Our open platform sends vehicle data directly to your own fleet management software for analysis, so you're not locked into a proprietary system.

Telogis®

Advanced fleet management and compliance tools that integrate directly with GuardDog® Connect or your own smartphone, tablet or other connected device.

Omnitracs

Real-time data on your vehicles' locations and how they're being driven so you can spot trends, reduce costs and manage drivers. No additional hardware needed.

Geotab®

Business intelligence and benchmarking data for older fleets to improve productivity, reduce fuel consumption, enhance driver safety and improve compliance.



Connected Support

Your trucks are only profitable when they're on the road and on the job. Maximize your uptime with intelligent maintenance systems and time-saving repair processes.

Over the Air (OTA) Software & Parameter Updates

Wirelessly updates software without disrupting your schedules, while increasing operational efficiency and uptime. Requires Mack® GuardDog® Connect.

Mack® GuardDog® Connect

Automatically monitors truck performance and quickly alerts OneCall® of any maintenance or repair needs. OneCall's 24/7 support and roadside assistance leverages Mack® ASIST to give drivers, dealers and Uptime Center staff access to key repair information—all while you're still on the road.

Preventive Maintenance

Keeps your trucks in top shape by planning a service schedule that matches the usage and miles of your vehicle, so we can repair or replace a component before it impacts your business.



Connected Driving

The trucking business is all about making margins and driving efficiency. Get the most out of your trucks and your drivers with built-in fuel management and driver assist technologies like Mack® Predictive Cruise.

Mack Predictive Cruise

Proprietary Mack technology that stores hilly terrain in GPS data to optimize engine speed and fuel efficiency on saved routes.

Information and Entertainment

Bluetooth®, satellite radio, cell phone integration and more to make life on the road as enjoyable as possible.

Bendix® Wingman® Fusion™

Driver assist and safety technology combining radar, camera, brakes and the SafetyDirect® web portal from the leader in collision mitigation.

Roll Stability

The Bendix® ESP® full-stability system helps drivers mitigate rollovers and loss-of-control in situations on wet and dry roadways through advanced sensors and throttle and braking interventions.

Collision Avoidance

Automatically alerts the driver and, if needed, applies the foundation brakes to mitigate or prevent a potential collision with a forward moving vehicle or stationary object.

Support at every turn.

Nearly 600 authorized dealers and parts and service locations coast to coast. Nearly 1,400 Master Technicians. When you need assistance, the Mack® network is ready to deliver.

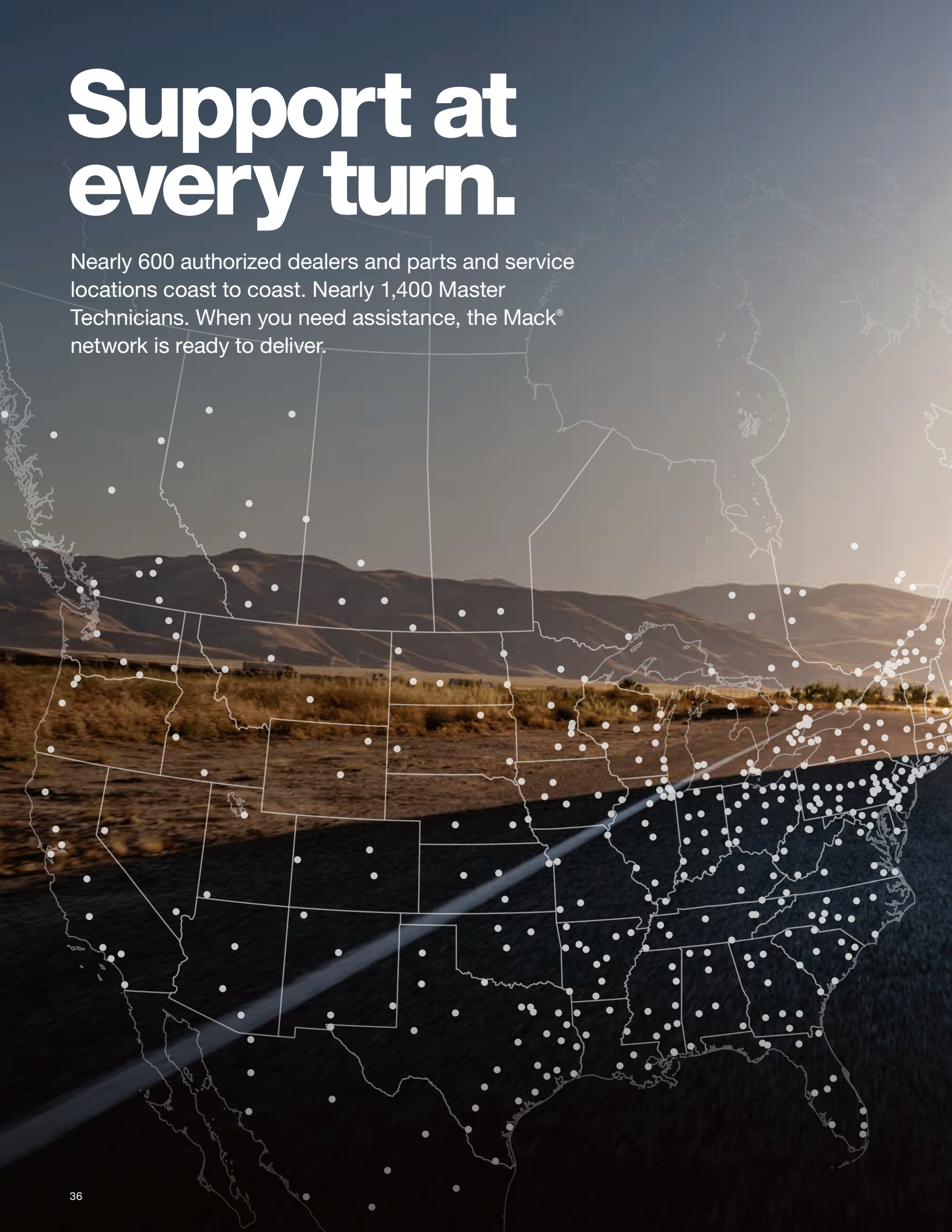



Certified Uptime Centers

Average trucking industry dwell time for a repair is 4 days, but the average repair actually takes less than 4 hours. Mack's Certified Uptime Centers identify the quick fixes and put them in the fast lane for completion, while giving larger repairs the attention they need.

Investing in Service

The Mack Dealer Network is committed to quick, quality service. That's why our dealers have invested nearly \$600 million since 2010 to modernize facilities, improve access to parts and train service professionals to help get you back on the road.

Family Experience

Whether you're behind the wheel or managing the fleet, when you run with Mack, you're part of the family. That means you'll always get personalized attention and the support you need to keep your business running strong. Just pick up the phone; there's always a real person ready at the other end of the line. Mack OneCall®: 1-800-866-1177.



Your business. On your terms.

You know your business better than anyone. So Mack Business Services offers you dedicated experts and flexible terms to help get into a Mack® and get out on the road.

Mack Financial services

Mack offers comprehensive financial services that include customized loans, leases and payment plans. You choose the terms, then Mack comes up with the payment plan and coverage that works for you, so you can build your business.

Warranty and Protection Plans

Mack offers the most flexible warranty program in the industry. Whether you need a standard warranty or a premium protection plan, Mack can customize a plan to meet your specific business requirements.

Mack Leasing System

Mack offers full-service leasing and rental services backed by our growing association of MLS dealer members. Whether you're looking to lease your fleet, rent a truck or outsource your maintenance, Mack has a variety of solutions to meet your needs.







1-800-922-MACK
MackTrucks.com

©2018 Mack Trucks, Inc.

 facebook.com/MackTrucks

 twitter.com/MackTrucks

 youtube.com/MackTrucks

 linkedin.com/company/mack-trucks

 plus.google.com/+macktrucks